

Baoli

KBE 25-35

KBE 25-35Li



1.1	Manufacturer		KION BAOLI
1.2	Manufacturer's type designation		KBE 35Li G1
1.3	Drive: electric, diesel, petrol, fuel gas		Electric
1.4	Operator type: hand, pedestrian, standing, seated, order-picker		Seated
1.5	Rated capacity / Rated load	Q (t)	3.5
1.6	Load centre distance	c (mm)	500
1.8	Load distance, centre of drive axle to fork	x (mm)	509
1.9	Wheelbase	y (mm)	1785
2.1	Service weight	Kg	5500
2.2	Axle loading, laden front/rear	Kg	7930/1070
2.3	Axle loading, unladen front/rear	Kg	2430/3068
3.1	Tyres: solid rubber, superelastic, pneumatic, polyurethane		S/E
3.2	Tyre size, front		28X9-15
3.3	Tyre size, rear		6.5-10
3.5	Wheels, number front/rear (x = driven wheels)		2x/2
3.6	Tread, front	b10 (mm)	1030
3.7	Tread, rear	b11 (mm)	953
4.1	Tilt of mast/fork carriage forward/backward	α/β (°)	6/10
4.2	Height, mast lowered	h1 (mm)	2137
4.3	Free lift	h2 (mm)	150
4.4	Lift	h3 (mm)	3000
4.5	Height, mast extended	h4 (mm)	4045
4.7	Height of overhead guard (cabin)	h6 (mm)	2230
4.8	Seat height/stand height	h7 (mm)	1238
4.12	Coupling height	h10 (mm)	705
4.19	Overall length	l1 (mm)	3738
4.20	Length to face of forks	l2 (mm)	2738
4.21	Overall width	b1/b2 (mm)	1268
4.22	Fork dimensions ISO 2331	s/e/l (mm)	50x150x1000
4.23	Fork carriage ISO 2328, class/type A, B		III A
4.24	Fork carriage width	b3 (mm)	1100
4.31	Ground clearance, laden, below mast	m1 (mm)	137
4.32	Ground clearance, centre of wheelbase	m2 (mm)	165
4.34.1	Aisle width for pallets 1000 x 1200 crossways	Ast (mm)	4109
4.34.2	Aisle width for pallets 800 x 1200 lengthways	Ast (mm)	4309
4.35	Turning radius	Wa (mm)	2400
4.36	Internal turning radius	b13 (mm)	672
5.1	Travel speed, laden/unladen	km/h	15/15
5.2	Lift speed, laden/unladen	m/s	0,370/0,440
5.3	Lowering speed, laden/unladen	m/s	0,370/0,440
5.8	Max gradeability, laden/unladen	%	16/20
5.10	Service brake		Mech/Hydr
6.1	Drive motor rating S2 60 min	kW	13.6
6.2	Lift motor rating at S3 15%	kW	21
6.4	Battery voltage/nominal capacity K5	V/Ah	80 / 412
6.5	Battery weight	kg	340
6.6	Energy consumption according to VDI cycle	kWh/h	6.5
10.1	Operating pressure for attachments	bar	200
10.7	Sound pressure level at driver's seat	dB (A)	68

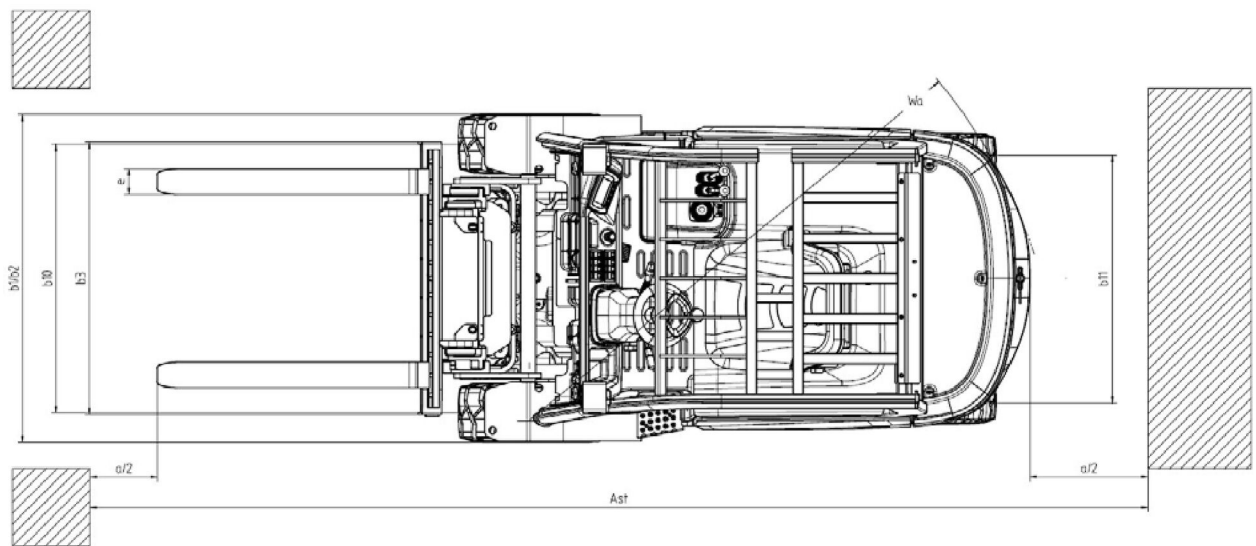
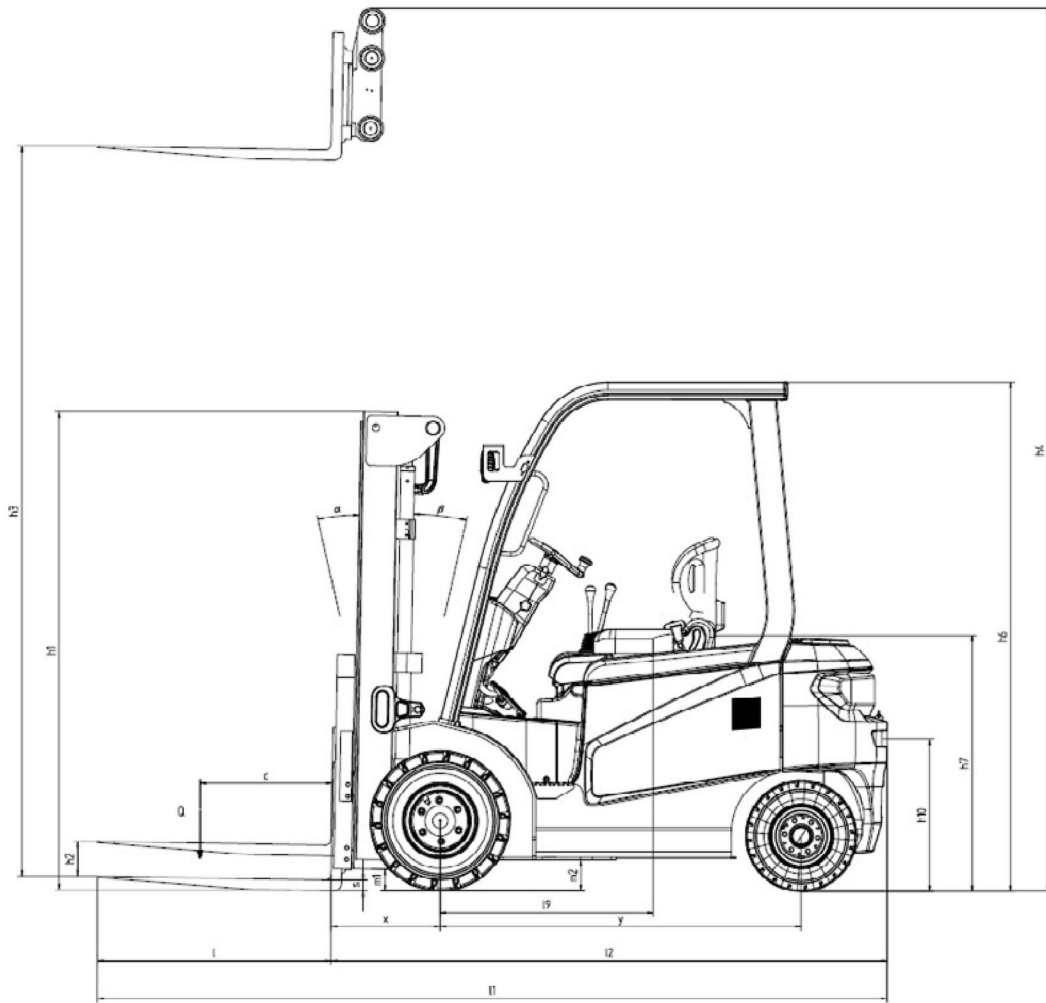

KBE 35Li G1

Mast type	H3	Capacity - Load center 500 mm	Capacity - Load center 500 mm - with IntegSideshift	Capacity - Load center 500 mm - with Hang on Sideshift	H1	H4	H2	Tilting angle Front/back
VM Tele	3000	3500	3500	3150	2147	3715	150	6/10
	3250	3500	3500	3150	2247	3965	150	6/10
	3500	3500	3500	3150	2447	4215	150	6/10
	4000	3500	3280	2950	2560	4715	150	6/6
	4500	3160	2850	2570	2997	5215	150	6/6
	5000	2690	2420	2180	3247	5715	150	6/6
	5500	2220	1980	1800	3497	6215	150	6/6
VFM 2 stage	3000	3500	3500	3150	2112	3752	1353	6/10
	3300	3500	3500	3150	2312	4052	1553	6/10
	3500	3500	3500	3150	2412	4252	1653	6/10
	4000	3500	3280	2950	2712	4752	1952	6/6
	4500	3160	2850	2570	2962	5252	2203	6/6
VFHM triplex	4350	3170	2990	2680	2162	5102	1403	6/6
	4500	3040	2870	2560	2212	5552	1453	6/6
	4650	2920	2740	2440	2212	5552	1453	6/6
	5000	2630	2450	2170	2412	5752	1653	6/6
	5500	2220	2030	1780	2662	6252	1903	6/6
	6000	1810	1610	1390	2912	6752	2153	6/6
	6500	1400	1200	1000	3112	7252	2353	6/6

KBE 25-35 KBE 25-35Li



The KBE 25-35 series is the perfect truck for all standard applications, bringing together productivity, high quality and cost effectiveness.

Manufactured in the „state-of-the-art“ KION production plant in Jinan, the KBE 25-35 is available with load capacities of 2,5, 3,0 and 3,5 t and is the perfect choice for almost all industries.

The solid workmanship combined with an uncompromising attention to the CE regulation, ensure a solid quality truck for customers whose safety is always a priority.

The newly designed mast, up to 6,5 meters high, ensures operators a very precise handling control and an excellent view of the load and surroundings.

The latest-generation KION controller manages the truck's functions, drawing the power from 80V/360-450Ah (2,5t) and 80V/500-600Ah (3,0-3,5t) batteries.

The KBE 25-35 is also available with lithium-ion batteries (80V/277-412Ah) as option.

Lithium batteries are virtually maintenance-free as don't need to be topped with water and increase the truck availability because short interim charging are allowed.

In addition, while the hydrogen produced by lead-acid batteries during charging can turn into dangerous gases, lithium-ion batteries eliminate this risk.

High quality electric motors and hydraulic components and the easy-to-read display, which provides the driver important information about the truck's status, guarantee additional comfort and reliability.

For smooth servicing procedures, the truck provides easy access to all components. The KBE features a newly developed diagnostics tool, operated via an app on a smartphone.

Technology

- ✓ Maintenance-free AC technology
- ✓ New generation KION controller
- ✓ Lithium-ion battery available: increased truck availability, no maintenance, no hazardous gases during charging
- ✓ High quality electric motors and hydraulics components
- ✓ 3 selectable driving programs: economy, efficiency, performance
- ✓ New diagnostic tool operated with a mobile phone thanks to the KEYS app
- ✓ Regenerative braking
- ✓ Robust mast options: two stages, two stages free lift, three stages free lift
- ✓ Fork speed reduction when lowering
- ✓ Hang-on or integrated side-shifter: fast loading and unloading
- ✓ High visibility LED lights
- ✓ Foot-activated parking brake

Ergonomics and driver's workplace

- ✓ Perfect visibility in all directions thanks to optimized mast and overhead guard sections
- ✓ Very comfortable and spacious operator compartment
- ✓ Standard overhead guard retrofittable to half and full cabin
- ✓ Electronic driving direction selector
- ✓ Very spacious footplate
- ✓ Storage compartments and USB ports for charging mobile devices
- ✓ Half and full cabin availability

- ✓ Color screen display with full information on truck status
- ✓ Side hydraulic levers
- ✓ Adjustable seat and steering column

