

Baoli

ES 16-N02

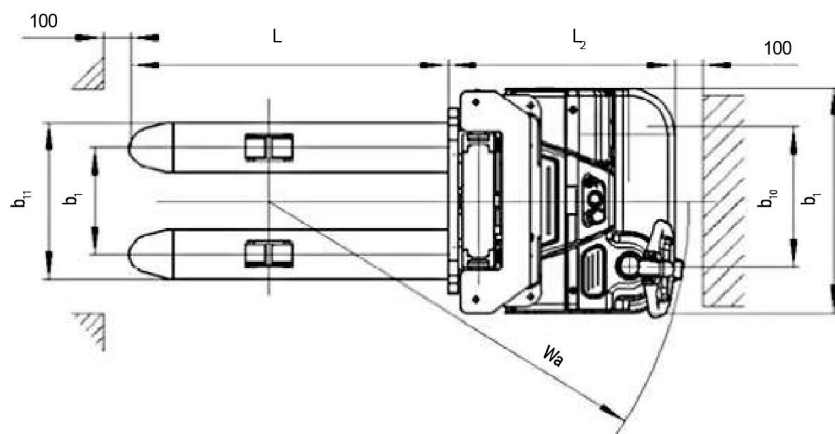

1.1	Manufacturer		KION BAOLI
1.2	Manufacturer's type designation		ES 16-N02
1.3	Drive: electric, diesel, petrol, fuel gas		Electric
1.4	Operator type: hand, pedestrian, standing, seated, order-picker		Pedestrian
1.5	Rated capacity / Rated load	Q (t)	1.6
1.6	Load centre distance	c (mm)	600
1.8	Load distance, centre of drive axle to fork	x (mm)	647
1.9	Wheelbase	y (mm)	1293
2.1	Service weight	Kg	1340
2.2	Axle loading, laden front/rear	Kg	930/2010
2.3	Axle loading, unladen front/rear	Kg	850/490
3.1	Tyres: solid rubber, superelastic, pneumatic, polyurethane		PU
3.2	Tyre size, front		Ø 230x70
3.3	Tyre size, rear		Ø 85x75
3.4	Additional wheels (dimensions)		Ø150x54
3.5	Wheels, number front/rear (x = driven wheels)		1x+1/4
3.6	Tread, front	b10 (mm)	522
3.7	Tread, rear	b11 (mm)	390/505
4.2	Height, mast lowered	h1 (mm)	2108
4.3	Free lift	h2 (mm)	1520
4.4	Lift	h3 (mm)	4530
4.5	Height, mast extended	h4 (mm)	5088
4.9	Height drawbar in driving position min/max	h14 (mm)	850/1385
4.15	Height, lowered	h13 (mm)	90
4.19	Overall length	l1 (mm)	1964
4.20	Length to face of forks	l2 (mm)	814
4.21	Overall width	b1/b2 (mm)	820
4.22	Fork dimensions ISO 2331	s/e/l (mm)	60/180/1150
4.25	Distance between fork-arms	b5 (mm)	570/685
4.32	Ground clearance, centre of wheelbase	m2 (mm)	28
4.34.1	Aisle width for pallets 1000 x 1200 crossways	Ast (mm)	2406
4.34.2	Aisle width for pallets 800 x 1200 lengthways	Ast (mm)	2329
4.35	Turning radius	Wa (mm)	1510
5.1	Travel speed, laden/unladen	km/h	5,7/6,0
5.2	Lift speed, laden/unladen	m/s	0,130/0,200
5.3	Lowering speed, laden/unladen	m/s	0,250/0,170
5.8	Max gradeability, laden/unladen	%	6/12
5.10	Service brake		Electromagnetic
6.1	Drive motor rating S2 60 min	kW	1.3
6.2	Lift motor rating at S3 15%	kW	3.2
6.3	Battery according to DIN 43531/35/36 A, B, C, no		3VBS
6.4	Battery voltage/nominal capacity K5	V/Ah	24/270
6.5	Battery weight	kg	230
6.6	Energy consumption according to VDI cycle	kWh/h	1.59
8.1	Type of drive unit		AC
10.7	Sound pressure level at driver's seat	dB (A)	<70

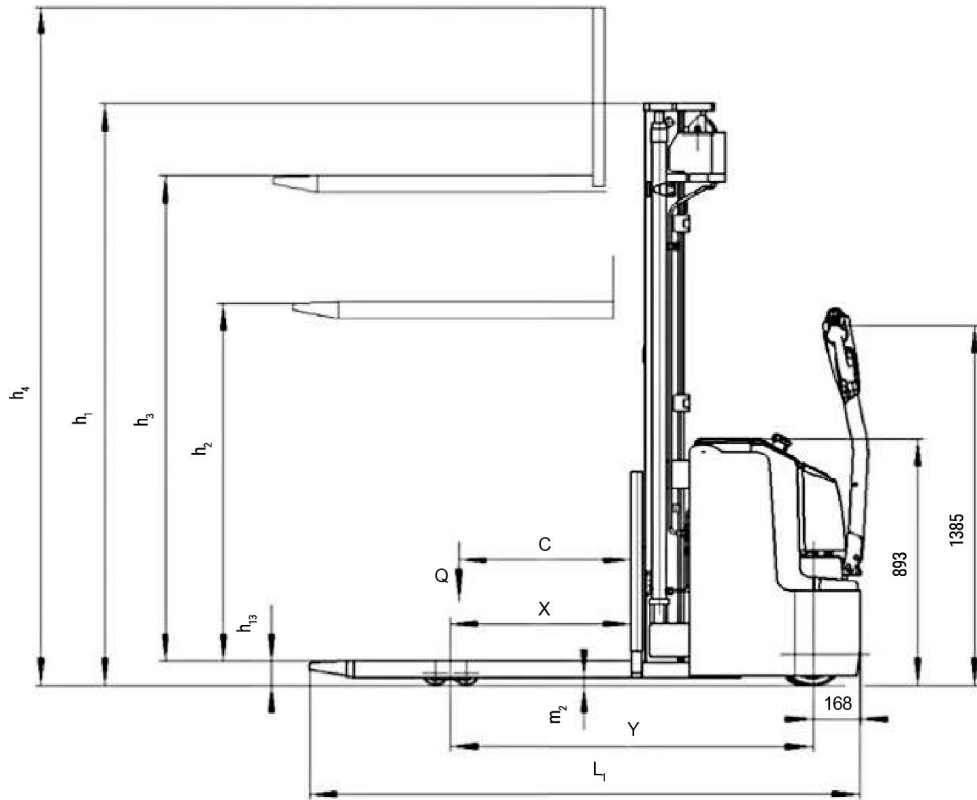

ES 16-N02

Mast	2 stages 2900mm	2 stages 3200mm	2 stages 3600mm	2 stages with free lift 2900mm	2 stages with free lift 3200mm	2 stages with free lift 3600mm	3 stages 4300mm	3 stages 4600mm	3 stages with free lift 4300mm	3 stages with free lift 4600mm	3 stages with free lift 5500mm
H1	1958	2108	2308	1958	2108	2308	2008	2108	2008	2108	2408
H2	-	-	-	1410	1560	1760	-	-	1420	1520	1820
H3	2830	3130	3530	2830	3130	3530	4230	4530	4230	4530	5340
H4	3380	3680	4080	3380	3680	4080	4780	5080	4780	5080	5980
H3 + H13	2920	3220	3620	2920	3220	3620	4320	4620	4320	4620	5520

ES 16-N02		
2900 mm		
H3 (mm)	Q (kg)	
2900	1400	1100
2500	1600	1200
c (mm)	600	700

ES 16-N02		
3200 mm		
H3 (mm)	Q (kg)	
3200	1200	900
2900	1400	1100
2500	1600	1200
c (mm)	600	700

ES 16-N02		
3600 mm		
H3 (mm)	Q (kg)	
3600	1000	700
3200	1200	900
2900	1400	1100
2500	1600	1200
c (mm)	600	700

ES 16-N02		
4300 mm		
H3 (mm)	Q (kg)	
4300	900	600
3600	1000	700
3200	1200	900
2900	1400	1100
2500	1600	1200
c (mm)	600	700

ES 16-N02		
4600 mm		
H3 (mm)	Q (kg)	
4600	800	500
4300	900	600
3600	1000	700
3200	1200	900
2900	1400	1100
2500	1600	1200
c (mm)	600	700

ES 16-N02		
5500 mm		
H3 (mm)	Q (kg)	
5500	600	350
4600	800	500
4300	900	600
3600	1000	700
3200	1200	900
2900	1400	1100
2500	1600	1200
c (mm)	600	700

ES 12-N03 - ES 16-N02



The Baoli ES 12-N03 and ES 16-N02 pallet stackers are perfect for the transport and storage of loads from 1200 to 1600 kg.

The ES 12-N03 features a 24 V / 180 Ah lead acid battery. The ES16-N02 is equipped with a higher capacity battery of 24 V / 270 Ah.

Thanks to the sensitive operation and proportional operating controls, these pallet stackers provide high handling efficiency.

The long tiller arm ensures optimal and highly ergonomic control of the vehicle. It requires less operating force and allows the driver to always keep an optimal distance from the vehicle.

Sturdy construction quality and high technological standards make the ES 12-N03 and ES 16-N02 pallet stackers a real benchmark in their sector. These pallet stackers impress with maximum efficiency and reduced maintenance costs.

Technology and features

- ✓ AC technology
- ✓ High quality components
- ✓ Electronics protected against water and dirt
- ✓ Perfect driving modulation
- ✓ Robust four-support-points chassis
- ✓ Two and three stages masts available
- ✓ Up to 5500 mm lifting height
- ✓ Forks with an overall width of 570 or 685 mm available
- ✓ Low-mounted tiller for less manoeuvring effort
- ✓ Automatic lift slowdown at maximum height

